

NitraVis 700/1 IQ NitraVis 700/5 IQ MIQ/VIS

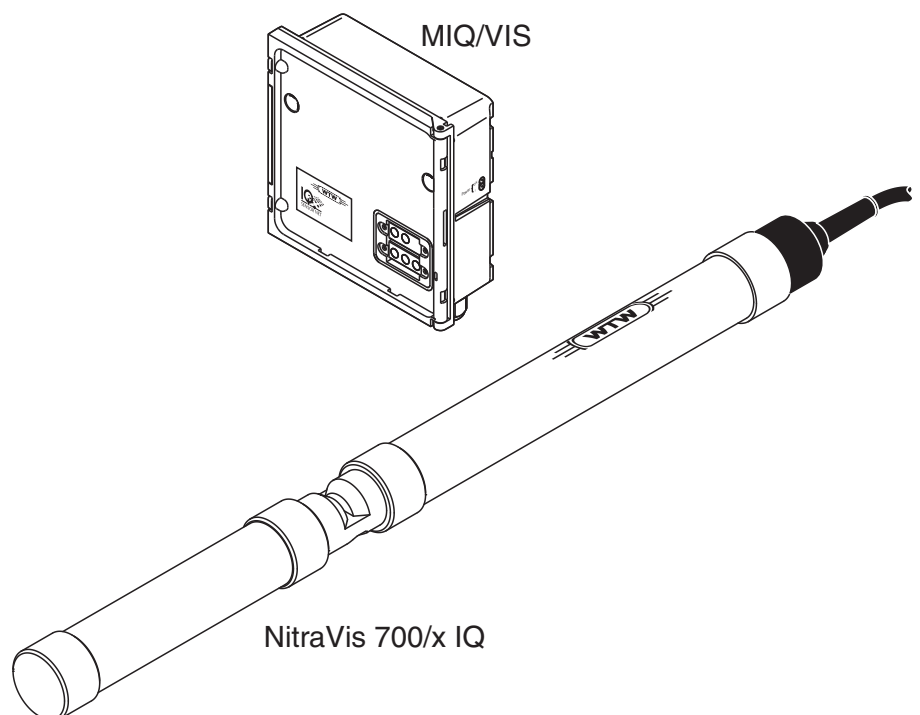

**NitraVis 700/1 IQ
NitraVis 700/5 IQ**

**Optical sensor for the spectral
determination of nitrate**

MIQ/VIS

Connection module for optical sensors

**Accuracy when going to
press**

The use of advanced technology and the high quality standard of our products are the result of continuous development. This may result in differences between this operating manual and your instrument. Also, we cannot guarantee that there are absolutely no errors in this manual. Therefore, we are sure you will understand that we cannot accept any legal claims resulting from the data, figures or descriptions.



Note

The latest version of the present operating manual can be found on the Internet under www.WTW.com.

Copyright

© Weilheim 2008, WTW GmbH
Reprinting - even as excerpts - is only allowed with the explicit written authorization of WTW GmbH, Weilheim.
Printed in Germany.

1	Overview	1-1
1.1	How to use this component operating manual	1-1
1.2	Field of application	1-2
1.3	Measuring principle of the UV/VIS sensor	1-2
1.4	Structure of the UV/VIS sensor	1-3
1.5	The NitraVis 700/x IQ in the IQ SENSOR NET	1-4
1.6	Instrument identification	1-4
2	Safety	2-1
2.1	Authorized use	2-2
2.2	General safety instructions	2-2
3	Commissioning	3-1
3.1	System requirements of the IQ SENSOR NET	3-1
3.2	Scope of delivery of the NitraVis 700/x IQ	3-1
3.3	Scope of delivery of the MIQ/VIS	3-1
3.4	Installation	3-2
3.4.1	Main steps for installation	3-2
3.4.2	Mounting the sensor	3-3
3.4.3	Mounting the MIQ/VIS + MIQ/CHV in the IQ SENSOR NET	3-4
3.4.4	Connecting the compressed air hose	3-5
3.4.5	Electrical connection	3-7
3.5	Initial commissioning	3-9
3.5.1	General information	3-9
3.5.2	Settings	3-10
3.6	Reading out software versions	3-16
4	Measuring / operation	4-1
4.1	Determination of measured values	4-1
4.2	Measurement operation	4-2
4.3	Calibration	4-3
4.3.1	Overview	4-3
4.3.2	User calibration	4-6
4.3.3	<i>Sensor check/Zero adjustment</i>	4-9
4.3.4	Sensor check with standard solutions	4-13
5	Maintenance and cleaning	5-1
5.1	Maintenance	5-1
5.2	Cleaning	5-1
5.2.1	Cleaning the MIQ/VIS	5-1
5.2.2	Compressed air driven cleaning of the measurement windows	5-1
5.2.3	Cleaning the sensor	5-1
5.3	Disposal	5-2

6	Spare parts, maintenance equipment, accessories	6-1
7	What to do if...	7-1
8	Technical data	8-1
8.1	Sensor	8-1
8.1.1	General data	8-1
8.1.2	Electrical data	8-2
8.1.3	Measurement conditions	8-2
8.1.4	Measuring ranges and resolution	8-3
8.2	MIQ/VIS	8-4
9	Indexes	9-1
9.1	Explanation of the messages	9-1
9.1.1	Error messages	9-1
9.1.2	Info messages	9-3
9.2	Status info	9-4
10	Appendix: Glossary	10-1

1 Overview

1.1 How to use this component operating manual

Structure of the IQ SENSOR NET operating manual

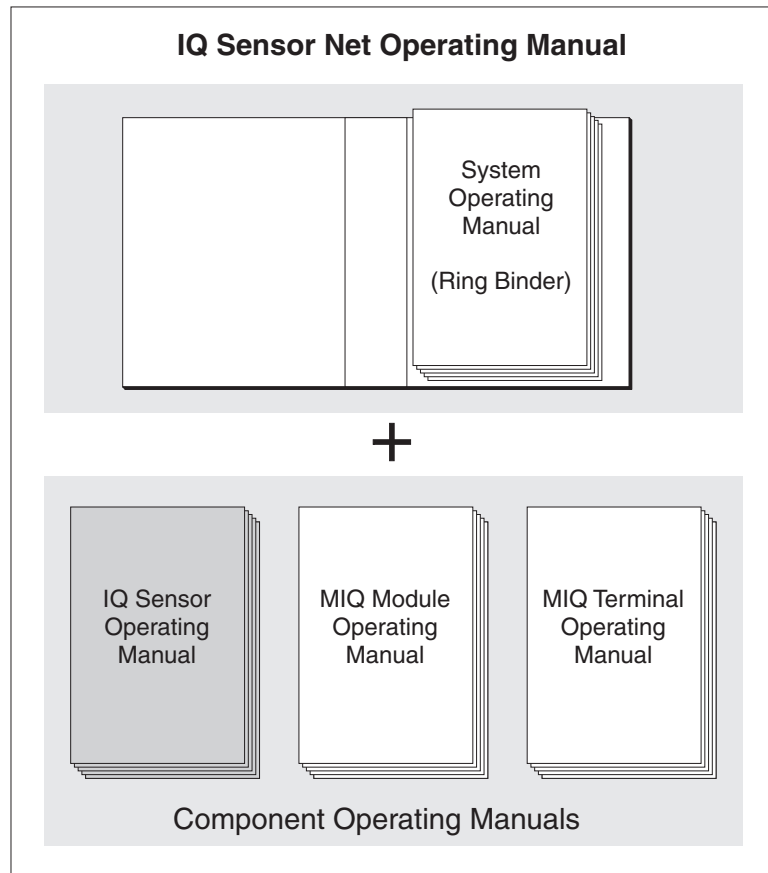

Fig. 1-1 Structure of the IQ SENSOR NET operating manual

The IQ SENSOR NET operating manual has a modular structure like the IQ SENSOR NET itself. It consists of a system operating manual and the operating manuals of all the components used.

Please file this component operating manual in the ring binder of the system operating manual.

1.2 Field of application

The NitraVis 700/x IQ is an online sensor for the in-situ determination of nitrate in waste water treatment plants. The range of application comprises control, feedback control and monitoring.

Measuring locations

NitraVis 700/1 IQ: Inlet or aeration tank

NitraVis 700/5 IQ: Outlet

Compressed air cleaning

The NitraVis 700/x IQ is prepared for the connection of a compressed air-driven cleaning system. The cleaning system works effectively. It is maintenance free and wear free.

1.3 Measuring principle of the UV/VIS sensor

The UV/VIS sensor operates according to the measuring principle of UV/VIS spectrometry.

Any substance contained in a measuring solution attenuates a light beam that penetrates the measuring solution. The attenuation (absorbance) of the light beam is measured for different wavelengths. The wavelength dependent distribution produces the absorbance spectrum.

The wavelength range where an absorbance occurs characterizes the substance. The amount of the substance determines the extent of the absorbance.

The influence of typical interference matrix variants occurring at municipal waste water treatment plants can be eliminated by including the entire absorbance spectrum.

With this measuring principle, measuring does not take place continuously but at intervals.

1.4 Structure of the UV/VIS sensor

A UV/VIS sensor contains a light source (1), a measuring gap (3) to enable the contact of light with the measuring solution, and a detector (5) to measure the attenuated light beam.

The sender of the optical system (2) directs a light beam, the measuring beam (6), through the measuring solution and a second light beam, the reference beam (8), over a distance without measuring solution. The test sample is between both measuring windows (3) in the measuring gap.

The receiver of the optical system (4) directs the measuring beam and reference beam to the detector. In the detector, the light is received by fixed photo diodes.

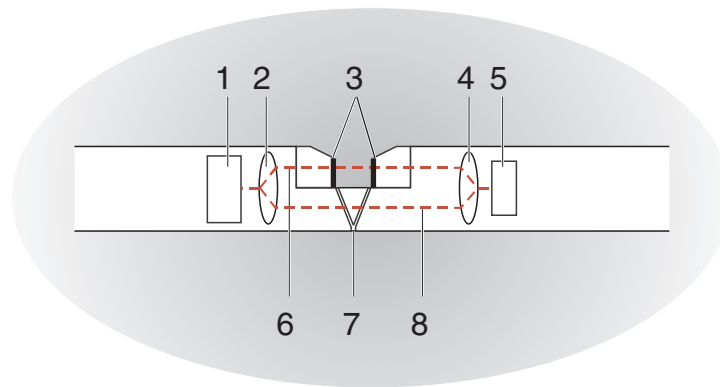

Fig. 1-2 Structure of a UV/VIS sensor

1	Light source
2	Sender of the optical system
3	Measuring gap between the measuring windows
4	Receiver of the optical system
5	Detector
6	Measuring beam
7	Cleaning nozzles of the compressed air cleaning system
8	Reference beam

1.5 The NitraVis 700/x IQ in the IQ SENSOR NET

The following overview shows the integration of the NitraVis 700/x IQ with cleaning system in the IQ SENSOR NET.

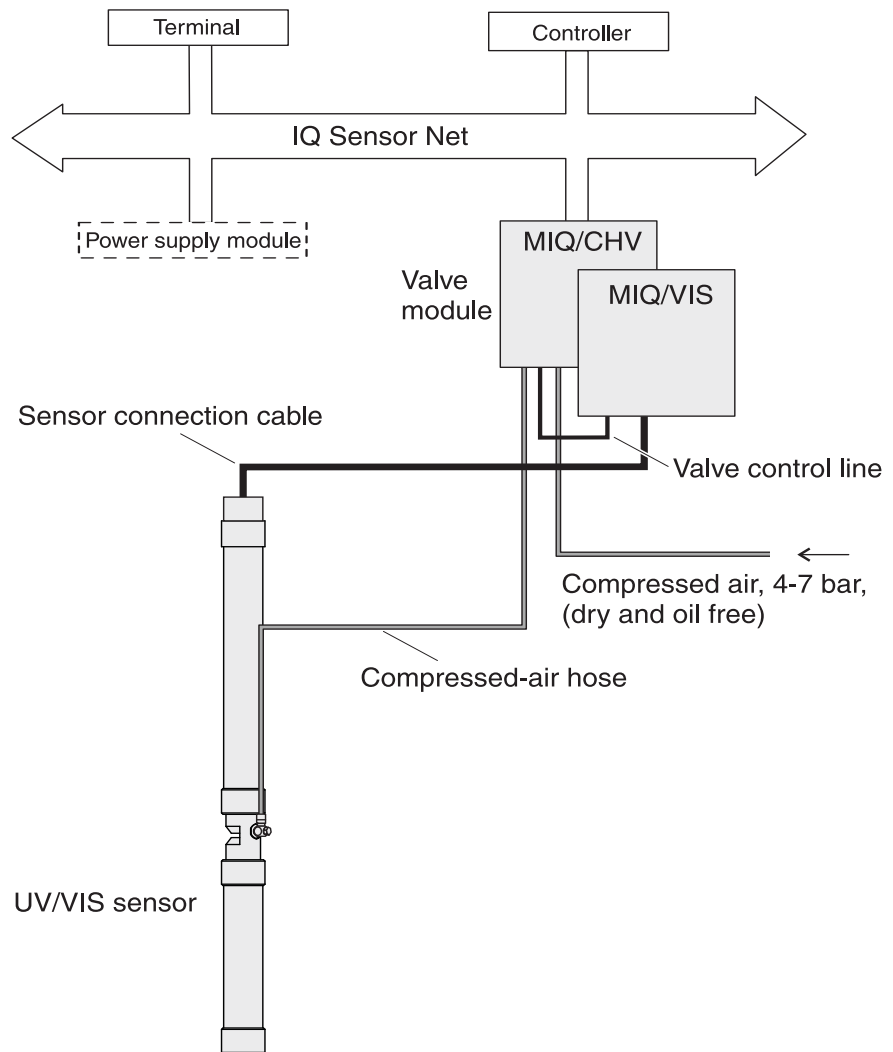

Fig. 1-3 The NitraVis 700/x IQ in the IQ SENSOR NET

1.6 Instrument identification

A name plate with the exact designation and series number of the UV/VIS sensor is fixed on the sensor cable. The name plates of the IQ SENSOR NET modules are on the lateral outside of the enclosures.

2 Safety

This component operating manual contains special instructions that must be followed in the operation of the NitraVis 700/x IQ sensor. Thus, it is essential to read this component operating manual before carrying out any work using this sensor. In addition to this manual, the SAFETY chapter of the IQ SENSOR NET system operating manual must be followed.

Always keep this component operating manual together with the system operating manual and any other component operating manuals in the vicinity of the IQ SENSOR NET system.

Special user qualifications

The NitraVis 700/x IQ was developed for applications in online measurement - essentially in the field of wastewater treatment. Thus, we assume that the operators are familiar with the necessary precautions to take when dealing with chemicals as a result of their professional training and experience.

General safety instructions

Safety instructions of this operating manual can be recognized by the warning symbol (triangle) in the left-hand column. The signal word (e.g. "Caution") indicates the danger level:



Warning

Warning indicates instructions that must be followed precisely in order to prevent serious dangers to persons.



Caution

Caution indicates instructions that must be followed precisely in order to avoid slight injuries or damage to the instrument or the environment.

Other labels



Note

Note indicates notes that draw your attention to special features.



Note

Note indicates cross-references to other documents, e.g. operating manuals.

2.1 Authorized use

The authorized use of the NitraVis 700/x IQ consists of its use as a sensor in the IQ SENSOR NET.

The technical specifications according to chapter 8 TECHNICAL DATA must be observed. Only operation according to the instructions given in this operating manual is considered to be authorized.

Any other use is considered to be **unauthorized**. Unauthorized use invalidates any claims with regard to the guarantee.



Caution

Only operate the sensor together with the MIQ/VIS connection module.

Function and operational safety

2.2 General safety instructions

The sensor left the factory in a safe and secure technical condition.

The failure-free function and operational safety of the sensor is only guaranteed if the generally applicable safety measures and the special safety instructions in this operating manual are followed during its use.

The failure-free function and operational safety of the sensor is only guaranteed under the environmental conditions that are specified in chapter 8 TECHNICAL DATA.

The specified temperature (see chapter 8 TECHNICAL DATA) must be maintained during the operation and transport of the sensor. Protect the sensor, particularly against frost or overheating.



Caution

The sensor may only be opened by specialists authorized by WTW.

Safe operation

If safe operation is no longer possible, the sensor must be taken out of operation and secured against inadvertent operation.

Safe operation is no longer possible if the sensor:

- has been damaged in transport
- has been stored under adverse conditions for a lengthy period of time
- is visibly damaged
- no longer operates as described in this manual.

If you are in any doubt, contact the supplier of your sensor.

Obligations of the operator

The operator of the sensor must ensure that the following rules and regulations are followed when dealing with hazardous substances:

- EEC directives for protective labor legislation
- National protective labor legislation
- Safety regulations
- Safety data sheets of the chemical manufacturer.

3.4 Installation

3.4.1 Main steps for installation



Caution

The sensor may only be connected electrically and the valve control line may only be connected to the MIQ/VIS when the system is voltage-free (dead).

Installing the NitraVis 700/x IQ including the compressed air cleaning device comprises the following steps:

- Make sure there is enough system power available in the IQ SENSOR NET (see IQ SENSOR NET system operating manual).



Note

The NitraVis 700/x IQ including the compressed air cleaning device consume altogether 9 W power:

NitraVis 700/x IQ	6.5 W
MIQ/VIS	0.5 W
MIQ/CHV	2 W

- Make sure the allowed maximum cable length to the next power supply module is not exceeded (see system operating manual).
- Connect the compressed air hose to the NitraVis 700/x IQ (see section 3.4.4).
- Mount the sensor (see section 3.4.2)



Caution

The relay of the MIQ/VIS is unsuitable for switching the Cleaning Air Box compressed air cleaning module.

Operation of the Cleaning Air Box will destroy the MIQ/VIS.

The switching voltage required for the Cleaning Air Box (see Technical data of the Cleaning Air Box) exceeds the switching voltage of the MIQ/VIS (see section 8.2).

For cleaning, use the MIQ/CHV cleaning module.

- Mount the MIQ/VIS + MIQ/CHV in the IQ SENSOR NET (see section 3.4.3).
- Connect the compressed air hose to the MIQ/CHV (see section 3.4.4).
- Connect the sensor to the MIQ/VIS (see section 3.4.5).
- Connect the MIQ/CHV to the compressed air supply.
- Perform a function check for the cleaning function (see operating manual of the MIQ/CHV).

3.4.2 Mounting the sensor



Caution

The sensor is an optical precision instrument that is to be protected against shocks. Make sure the distances to the wall, bottom and other installation surroundings are sufficient. If necessary, protect the sensor from hitting with the protective ring provided. Attach the fixing elements on the thick sections of the sensor shaft only - never on the thin sensor pipe (40 mm pipe).



Caution

Always make sure the surface of the enclosure is not damaged by sharp-edged objects. The enclosure of the sensor may not touch any metallic objects in order to prevent contact corrosion.



Caution

Do not suspend the sensor on the sensor connection cable.

A wide range of mounting accessories is available for the installation of the NitraVis 700/x IQ (see chapter 6 SPARE PARTS, MAINTENANCE EQUIPMENT, ACCESSORIES). Thus, all prevalent ways of mounting are possible.

Generally, observe the following general rules when mounting the sensor at the measuring location:

Horizontal installation

When mounting the sensor horizontally, the measuring gap opening should be on the side. Thus, the compressed air can escape upward after cleaning and no sediment can collect in the measuring gap. The sensor should be aligned in parallel with the flow direction.

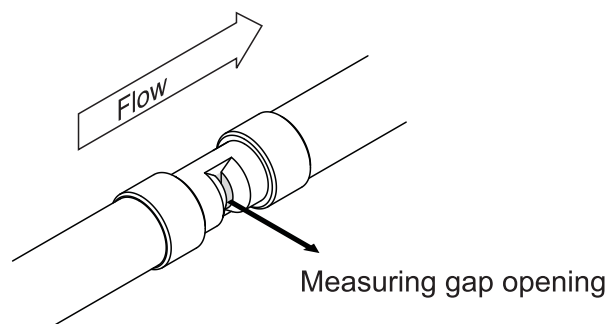

Fig. 3-1 Horizontal installation

Vertical installation

When mounting the sensor vertically, make sure that interfering elements in the measuring gap (e.g. air bubbles from the compressed air cleaning) can escape with the flow. In the case of vertical installation, the minimum flow rate is 0.2 m/s if the measuring gap should be kept clean optimally.

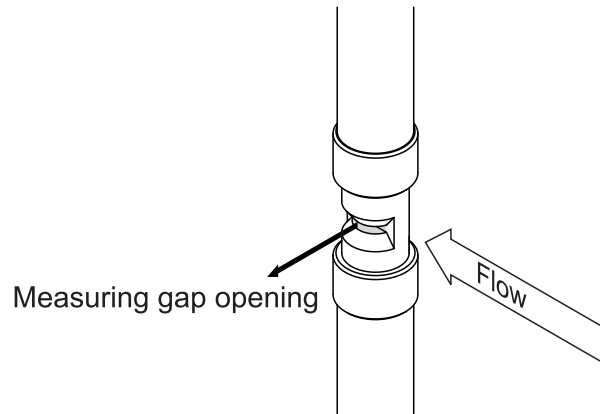

Fig. 3-2 Vertical installation

Protective ring

When installing the sensor, always make sure it cannot knock against a wall or another obstacle.

Make sure the safety margins are sufficient (e.g. with suspended mounting). If this is not possible due to the conditions at the installation location, protect the sensor with the protective ring supplied.

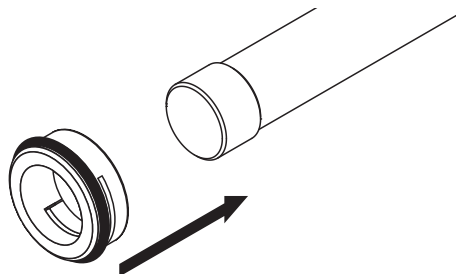

Fig. 3-3 Mounting the protective ring

3.4.3 Mounting the MIQ/VIS + MIQ/CHV in the IQ SENSOR NET

It is most functional to mount the MIQ/VIS and MIQ/CHV in the IQ SENSOR NET as a stack (MIQ/VIS with MIQ/CHV behind). The sensor cable and compressed air hose can be lead in parallel in this case.

The IQ SENSOR NET offers a variety of options to connect the module stack to the system (stack mounting, distributed mounting, etc.). The individual types of installation are described in detail in the INSTALLATION chapter of the system operating manual.

3.4.4 Connecting the compressed air hose

General instructions

Pay attention to the following instructions when connecting the compressed air hoses:

- Follow the specification of the compressed air according to chapter 8 TECHNICAL DATA.
- Only use the mounting material provided to connect the compressed air.

Mounting the compressed air hose on the sensor

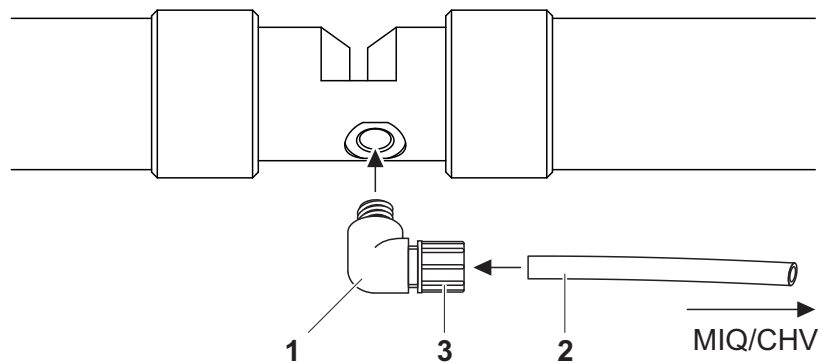

Fig. 3-4 Mounting the compressed air hose on the sensor

1	As shown in Fig. 3-4, screw-in the elbow joint (1).
2	Insert the thin end of the compressed air hose (2) in the elbow joint and tighten the lock nut (3).
3	Run the compressed air hose to the MIQ/CHV and cut it off at a suitable length as necessary. To prevent foreign bodies from getting caught, use cable ties at sufficiently short distances to attach the hose to the sensor and sensor suspension.

Connecting the compressed air hose to the MIQ/CHV

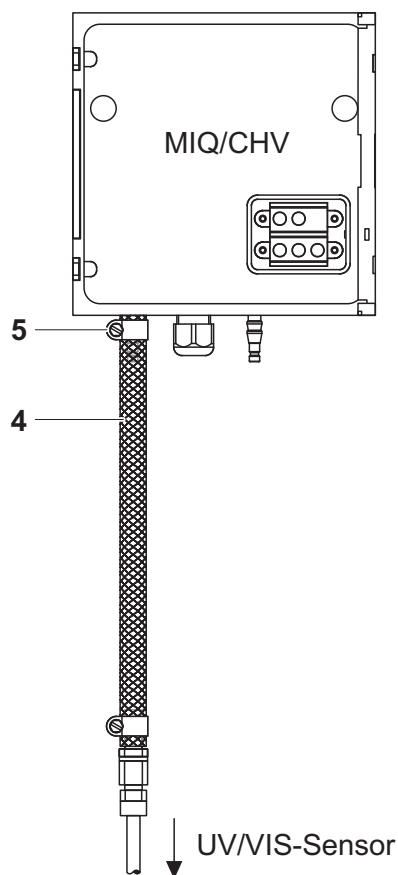

Fig. 3-5 Connecting the compressed air hose to the MIQ/CHV

- 4 Connect the other end of the compressed air hose (4) to the compressed air outlet of the MIQ/CHV. Secure the connection with a hose clip (5).

Note on opening the compressed air line



Pay attention to the following safety instruction if you want to open the compressed air line (e.g. during a modification):

Warning

Danger of injury from lines that are under pressure. Before opening the compressed air line, ensure that the section of line concerned is free of pressure. The compressed air glands in the housing of the MIQ/CHV may only be opened by a service technician authorized by WTW.

3.4.5 Electrical connection



Caution

The sensor may only be connected electrically and the valve control line may only be connected to the MIQ/VIS when the system is voltage-free (dead).



Caution

A UV/VIS sensor NitraVis 700/x IQ may only be connected to the IQ SENSOR NET via an MIQ/VIS module. Otherwise, the sensor will be damaged.

Connecting the sensor cable

- 1 Open the MIQ/VIS module.
- 2 Connect the sensor to the terminal strip of the MIQ/VIS. The cable colors must agree with the colors of the terminal labeling. The terminal labeling is on the bottom of the module.

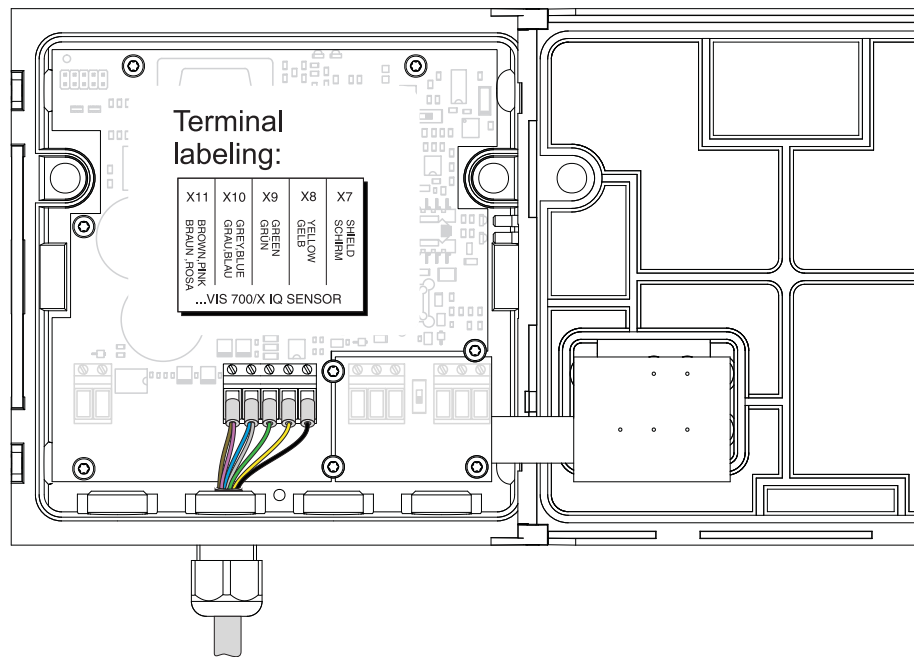

Fig. 3-6 Connecting the UV/VIS sensor in the MIQ/VIS

Connecting the valve control line

With the time-controlled compressed air cleaning function, the control valve in the MIQ/CHV is controlled by the MIQ/VIS. The two modules have to be connected via a two-wire control line for this. On the MIQ/VIS side, continue the installation as follows:

- 3 Strip the valve control line as necessary. Subsequently, strip both wires and attach wire end sleeves.
- 4 Connect both wires of the valve control line to the terminal strip of the MIQ/VIS. Follow the terminal labeling (Fig. 3-7).

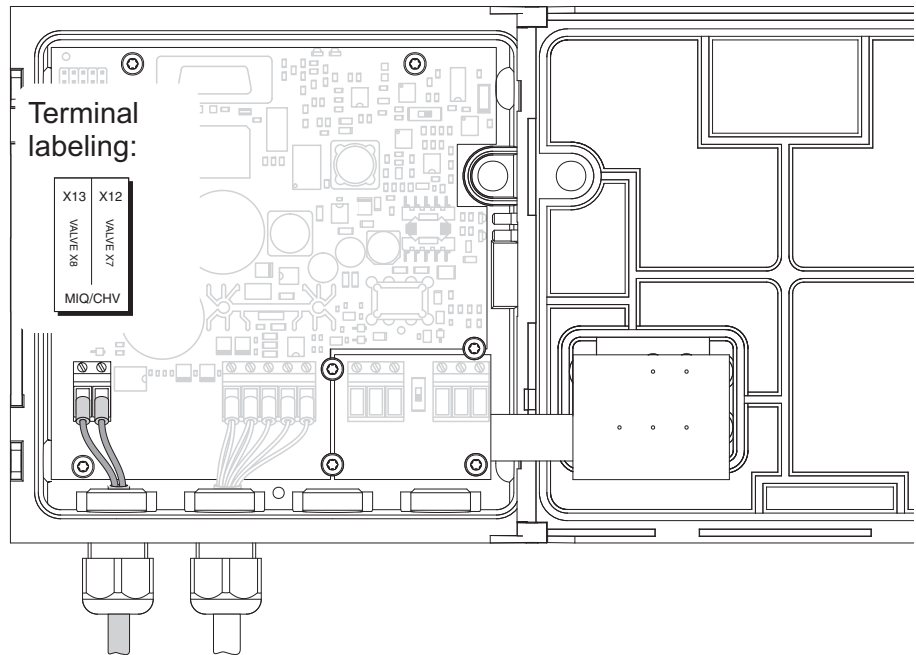

Fig. 3-7 Connection of the valve control line in the MIQ/VIS

- 5 Close the MIQ/VIS module.



Note

The connection on the MIQ/CHV side is described in the MIQ/CHV operating manual.

3.5 Initial commissioning

3.5.1 General information



Warning

Never look into the measuring window or put objects into the measuring window during operation! The emitted UV radiation can damage the eyes!

In the case of authorized use, inadvertent eye contact with the light beam is not possible.

The sensor is immediately ready to measure. The NitraVis 700/1 IQ sensor is prepared for operation in the aeration tank and precalibrated in the factory. For use in the inlet you only have to change the *Measuring location* setting.

The compressed air cleaning function is switched on in the factory. The first measuring cycle (cleaning and measuring) starts after initializing the sensor in the IQ SENSOR NET.



Note

How to adjust the settings is described in the following section (section 3.5.2).

Calibration after initial commissioning

On the basis of a reference measurement ("laboratory value"), check whether the default settings deliver sufficiently accurate measured values or whether you want to carry out a user calibration. If demands on the measuring accuracy are high, you should always carry out a *Sensor check/Zero adjustment* and a user calibration after the initial commissioning (see section 4.3 CALIBRATION).

3.5.2 Settings

Measuring cycle

A measuring cycle consists of the cleaning duration, the adjustment phase for the measuring system and the determination of the measured value. The following graphic demonstrates the relevant settings:

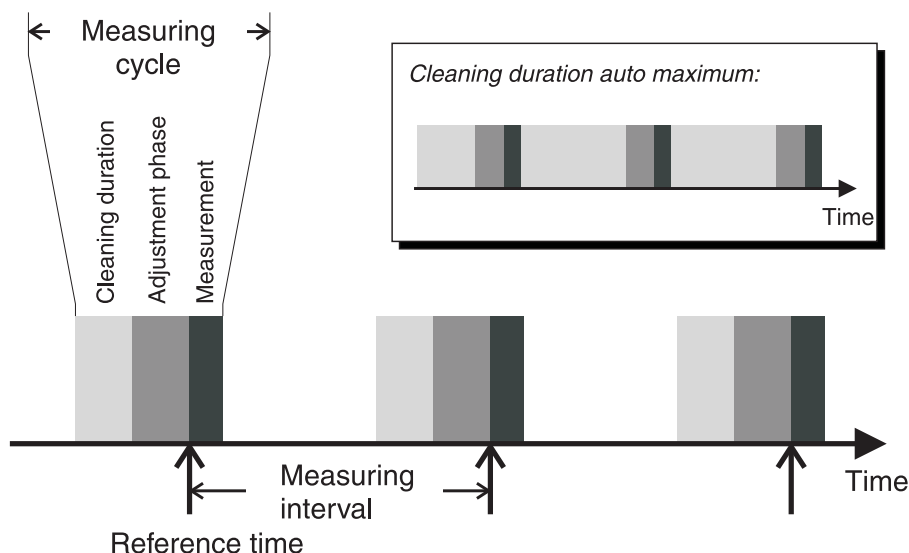

Fig. 3-8 Measuring cycle of the UV/VIS sensor



Note

Default values are marked in bold.

Menu item	Settings	Explanations
Measuring mode	<ul style="list-style-type: none"> ● NO3-N ● NO3 ● NO3-N standard 	<p>The measured variable is displayed in the selected citation form.</p> <p>The <i>NO3-N standard</i> setting is used for the sensor check with nitrate standard solutions (see section 4.3.4). In this measuring mode, the sensor automatically measures with the smallest possible measuring interval. The cleaning function and adjustment phase are not active in this mode. All ineffective settings (measuring interval, cleaning duration and adjustment phase etc.) are hidden.</p>

Menu item	Settings	Explanations
<i>Measuring location</i>	NitraVis 700/1 IQ: <ul style="list-style-type: none"> ● Activation ● <i>Inlet</i> NitraVis 700/5 IQ: <ul style="list-style-type: none"> ● <i>Outlet</i> (permanently set) 	Measurement location or application of the sensor. The sample matrix the calculation of the measured value is based on changes with the location of the sensor. This setting is not available for the <i>Measuring mode NO3-N standard</i> .
<i>Measuring range</i>	-	Display of the measuring range (see chapter 8 TECHNICAL DATA).
<i>Cal - # raw value 1</i>	Value pairs of the user calibration (see section 4.3.2). These settings are not available for the <i>Measuring mode NO3-N standard</i> . <u>Note:</u> Leave those values unchanged during the initial commissioning.	
<i>Cal - ref. value 1</i>		
<i>Cal - # raw value 2</i>		
<i>Cal - ref. value 2</i>		
<i>Ref. time (h)</i>	0 ... 12 ... 23 h	Time at which a measuring cycle is started. Further measuring cycles take place at intervals according to the specified measuring interval.
<i>Ref. time (min)</i>	0 ... 59 min	
<i>Meas. interval</i>	<i>Minimum, 5 10, 15, 30, 60 min</i>	Repetition of the measuring cycle at the specified interval. With the <i>Minimum</i> setting, the sensor automatically calculates the shortest possible measuring interval taking into account the settings for <i>Cleaning duration</i> and <i>Adjustment phase</i> . When the settings are quit with <i>Save and quit</i> , a log book message is generated that quotes the calculated time.
<i>Signal smoothing</i>	<ul style="list-style-type: none"> ● On ● <i>Off</i> 	Switching on/off the signal smoothing. For more details, see <i>Response time t90</i> . This menu item is only available if the <i>Meas. interval</i> is set to <i>Minimum</i> .

Menu item	Settings	Explanations
<i>Measuring location</i>	NitraVis 700/1 IQ: <ul style="list-style-type: none"> ● Activation ● <i>Inlet</i> NitraVis 700/5 IQ: <ul style="list-style-type: none"> ● <i>Outlet</i> (permanently set) 	Measurement location or application of the sensor. The sample matrix the calculation of the measured value is based on changes with the location of the sensor. This setting is not available for the <i>Measuring mode NO3-N standard</i> .
<i>Measuring range</i>	-	Display of the measuring range (see chapter 8 TECHNICAL DATA).
<i>Cal - # raw value 1</i>	Value pairs of the user calibration (see section 4.3.2). These settings are not available for the <i>Measuring mode NO3-N standard</i> . <u>Note:</u> Leave those values unchanged during the initial commissioning.	
<i>Cal - ref. value 1</i>		
<i>Cal - # raw value 2</i>		
<i>Cal - ref. value 2</i>		
<i>Ref. time (h)</i>	0 ... 12 ... 23 h	Time at which a measuring cycle is started. Further measuring cycles take place at intervals according to the specified measuring interval.
<i>Ref. time (min)</i>	0 ... 59 min	
<i>Meas. interval</i>	<i>Minimum, 5 10, 15, 30, 60 min</i>	Repetition of the measuring cycle at the specified interval. With the <i>Minimum</i> setting, the sensor automatically calculates the shortest possible measuring interval taking into account the settings for <i>Cleaning duration</i> and <i>Adjustment phase</i> . When the settings are quit with <i>Save and quit</i> , a log book message is generated that quotes the calculated time.
<i>Signal smoothing</i>	<ul style="list-style-type: none"> ● On ● <i>Off</i> 	Switching on/off the signal smoothing. For more details, see <i>Response time t90</i> . This menu item is only available if the <i>Meas. interval</i> is set to <i>Minimum</i> .

Menu item	Settings	Explanations
<i>Response time t90</i>	10 ... 60 min	Response time of the signal smoothing. Depending on the sample matrix, measured values can vary more or less strongly (e.g. due to foreign bodies or air bubbles). The signal filter reduces the limits of variation of the measured value. The signal filter is characterized by the <i>Response time t90</i> . This is the time after which 90 % of a signal change is displayed.
<i>Cleaning mode</i>	<ul style="list-style-type: none"> ● On ● <i>Off</i> 	Switching on/off the automatic, time-controlled compressed air cleaning function.
<i>Cleaning duration</i>	5, 10, 15, 20, 30, 60 s, or <i>Auto maximum</i>	Duration of the cleaning process. When <i>Auto maximum</i> is set, the compressed air cleaning system works with maximum cleaning power. The cleaning duration starts directly after the measured value determination and ends when the next adjustment phase begins (see Fig. 3-8).
<i>Adjustment phase</i>	5 ... 10 ... 30 s	The <i>Adjustment phase</i> setting is required to provide a time interval between the cleaning process and the next measurement. After the compressed air cleaning, air bubbles can possibly escape from the hose and interfere with the measurement.
<i>Meas. betw. cleaning</i>	1 ... 10	Number of measurements between two cleaning processes. We recommend the setting 1, i.e. a cleaning procedure takes place before each measurement.
<i>Software versions</i>	<ul style="list-style-type: none"> ● Do not download ● <i>Transmit to log book</i> 	Generates a log book message with all relevant software states of the sensor on leaving the settings with <i>Save and quit</i> (see section 3.6). When the menu is opened again, the setting is reset to <i>Do not download</i> .
<i>Save and quit</i>	-	The system confirms the saving of the settings and the display switches to the next higher level.

Menu item	Settings	Explanations
<i>Quit</i>	-	The display switches to the next higher level without saving the new settings.

Carrying out settings

1	Switch to the measured value display with (M) .
2	Open the <i>Settings</i> menu with (S) .
3	Select and confirm the menu item <i>Settings of sensors and diff. sensors</i> -> <i>Measuring range</i> column with (G) and (OK) .
4	Select the UV/VIS sensor with (C) .

Terminal PC 16 Okt 2003 00:01			
Settings of sensors and diff. sensors			140
&	No.	Sensor name	Measuring range
	S01	03090001	NO3-N 0.00..60.00 mg/l
	S02	99190001	LF AutoRange
	S03	01341000	O2 0 ... 60,0 mg/l
	S04	99160001	pH 0..14

Select **(C)**, edit sensor settings **(M)**

Fig. 3-9 140 - Settings of sensors and diff. sensors

5	Confirm the selection with (OK) . The settings of the sensor are displayed.
---	---

Terminal PC	16 Oct 2003 11 10	🔒 ⚠️ ⓘ
S01 NitraVis700/1IQ 03090001		
Measuring mode	N03-N	
Measuring location	Activation	
Measuring range	0.00..60.00 mg/L	
Cal - # raw value 1	0.00	
Cal - ref. value 1	0.00	
Cal - # raw value 2	10.00	
Cal - ref. value 2	10.00	
Ref. time (h)	12 h	
Ref. time (min)	0 min	
Meas. interval (min)	Minimum	
Signal smoothing	On	
Response time t90	10 min	
Cleaning mode	On	
Cleaning duration	10 s	
Adjustment phase	10 s	
Meas. betw. cleaning	1	
Software versions	Do not download	
Save and quit		
Quit		
Select setting ⏮		

(Example:
NitraVis 700/1 IQ)

Scroll with ⏮ to display these settings

Fig. 3-10 140 - Settings of sensors and diff. sensors

- | | |
|---|---|
| 6 | Make the sensor settings with ⏮ and confirm each of them with Ⓚ. |
| 7 | Select the <i>Save and quit</i> menu item with ⏮ and confirm with Ⓚ. The new settings are stored in the IQ SENSOR NET controller. |

3.6 Reading out software versions

In the IQ SENSOR NET system, the NitraVis 700/x IQ registers with the following active components:

- NitraVis 700/x IQ (sensor)
- MIQ/VIS (connection module)

The sensor appears in the list of sensors with the series number of the physical sensor (according to name plate).

Software versions of the sensor

The sensor has a separate software (measured value algorithm) for each measuring mode and measuring location. All relevant software versions can be output via a log book message. To do so, open the *Settings of sensors and diff. sensors* menu for the UV/VIS sensor and select the *Transmit to log book* option in the *Software versions* line (see section 3.5.2).

Software version of the MIQ/VIS

The software version of the MIQ/VIS can be displayed with the aid of the service function, *List of all components*. The function can be found in the *Settings* menu under *Service* (see system operating manual).

4 Measuring / operation

4.1 Determination of measured values

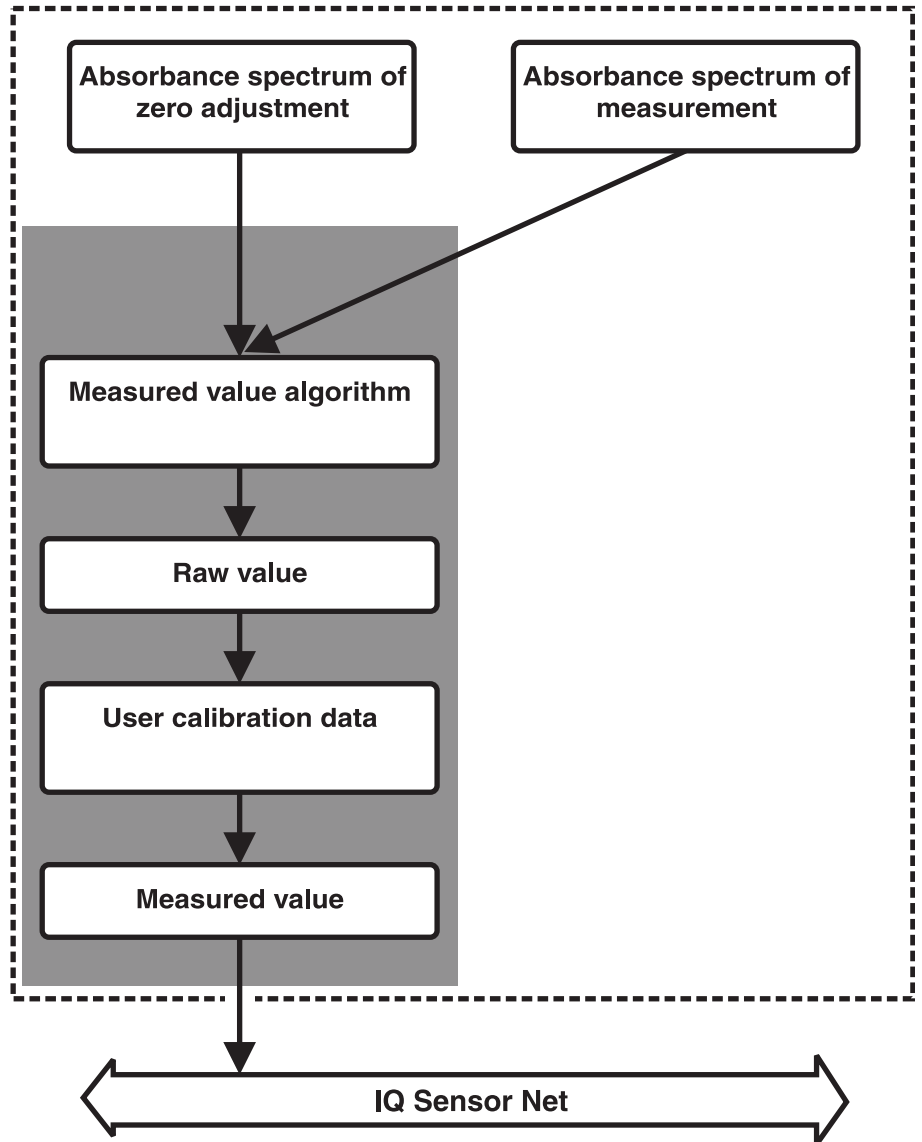

Fig. 4-1 Determination of measured values

During a measurement, the absorbance spectrum of the test sample is recorded and set against the stored absorbance spectrum of a zero adjustment (measurement in ultrapure water). The algorithm for the calculation depends on the selected application and/or the measuring location. The resulting raw value can be adjusted to an independent reference measurement with the aid of a so-called user calibration.

4.2 Measurement operation



Warning

Never look into the measuring window or put objects into the measuring window during operation! The emitted UV radiation can damage the eyes!

In the case of authorized use, inadvertent eye contact with the light beam is not possible.

Measured value display

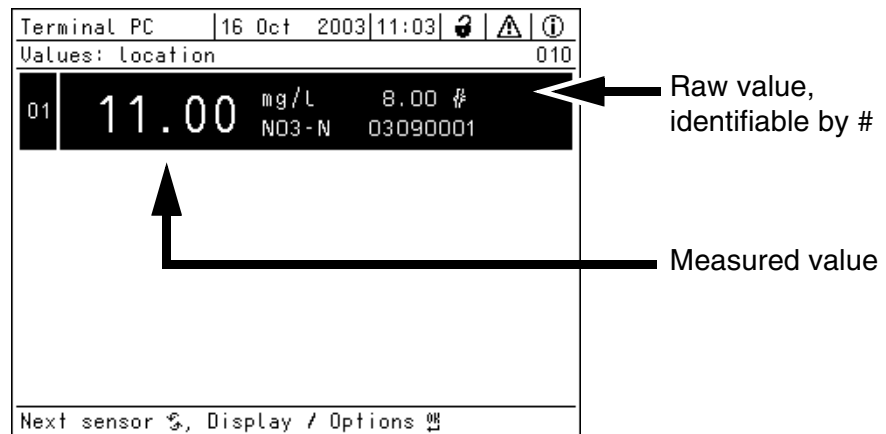

Fig. 4-2 NitraVis 700/x IQ sensor in the measured value display, example of fourfold display

Factors affecting the measured values

The following factors can affect the measurement quality:

- The measuring gap is not sufficiently filled and flowed through by test sample
- Foreign bodies and air bubbles are in the measuring gap
- Extraordinary changes (interferences) of the sample matrix
- The measuring window are contaminated due to a too low cleaning efficiency
- Failure of compressed air
- Damaged measuring windows
- Lacking quality of the zero adjustment, e.g. due to contaminated ultrapure water
- The user calibration is not representative (or erroneous)

4.3 Calibration

4.3.1 Overview

- User calibration (see section 4.3.2)
- *Sensor check/Zero adjustment* (see section 4.3.3).

An overview diagram on the calibration procedures can be found on page 4 - 5.

User calibration

With a user calibration you compensate for the influence of the test sample. The user calibration requires a successful *Sensor check/Zero adjustment*.

We recommend to check the current user calibration against independent comparison measurements if you suspect a basic change of the characteristics of the test sample. If the comparison measurements show clear deviations, these can be compensated for by a user calibration.

Sensor check

The characteristics of a sensor and thus the measured values provided by it change in the course of time.

The reasons for this can be the aging of the sensor, or contamination or mechanical damage of the sensor. Contamination or mechanical damage in the area of the measuring chamber or on the measurement windows affect the measured values.



Note

In UV/VIS spectroscopy, even very small contamination that is not visible to the eye can affect the measured value. The proper and thorough cleaning of the sensor is the basis for reliable measurement data.

A *Sensor check* determines the condition of the UV/VIS sensor. By checking the sensor with the aid of the *Sensor check* you can rapidly see changes of the sensor and whether it needs to be cleaned or if any other actions have to be taken.

A *Sensor check* should be carried out twice per year at regular intervals. An extraordinary *Sensor check* should be carried out if you suspect that the sensor has been damaged such as by mechanical shock, or if the measured values do not seem plausible.

Zero adjustment

While the *Sensor check* just determines the current state of the sensor, a *Zero adjustment* can be used to compensate for changes of the sensor. A zero adjustment can be required if, for example, the sensor check is not successful even after the sensor was thoroughly cleaned.



Note

The sensor should always be very thoroughly cleaned prior to a zero adjustment.

If the *Zero adjustment* is not successful, the sensor is blocked for measurement. A successful *Zero adjustment* is required for the determination of measured values.

Recalibration in case of change of measuring location



Note

Each time after the application or measurement location (and the setting, *Measuring location*) was changed, we recommend to carry out a *Sensor check* (and, if the sensor check was not successful, an additional *Zero adjustment* if necessary) with a subsequent *user calibration*.



Note

Normally, no new user calibration is required if the sensor is exchanged. The data of the user calibration are stored in the IQ SENSOR NET controller and thus assigned to the measuring location (not to the sensor). The calibration data of the *Zero adjustment* are stored in the sensor.

Steps of the sensor calibration (sensor check and zero measurement)

A successful sensor check is the prerequisite for a valid calibration. After each sensor check the sensor is evaluated. To narrow down the cause of a failed sensor check it is helpful to carry out the sensor check while the sensor is in different cleaning conditions.

Sensor check part 1	After cleaning the sensor housing, sensor sleeve and compressed air channels (without cleaning the measurement windows).
Sensor check part 2	After additionally cleaning the measurement windows (if the first sensor check was no successful)

This procedure enables to draw a conclusion on the level of contamination of the measurement windows. A changed sensor evaluation proves that the cleaning was effective.

Flowchart

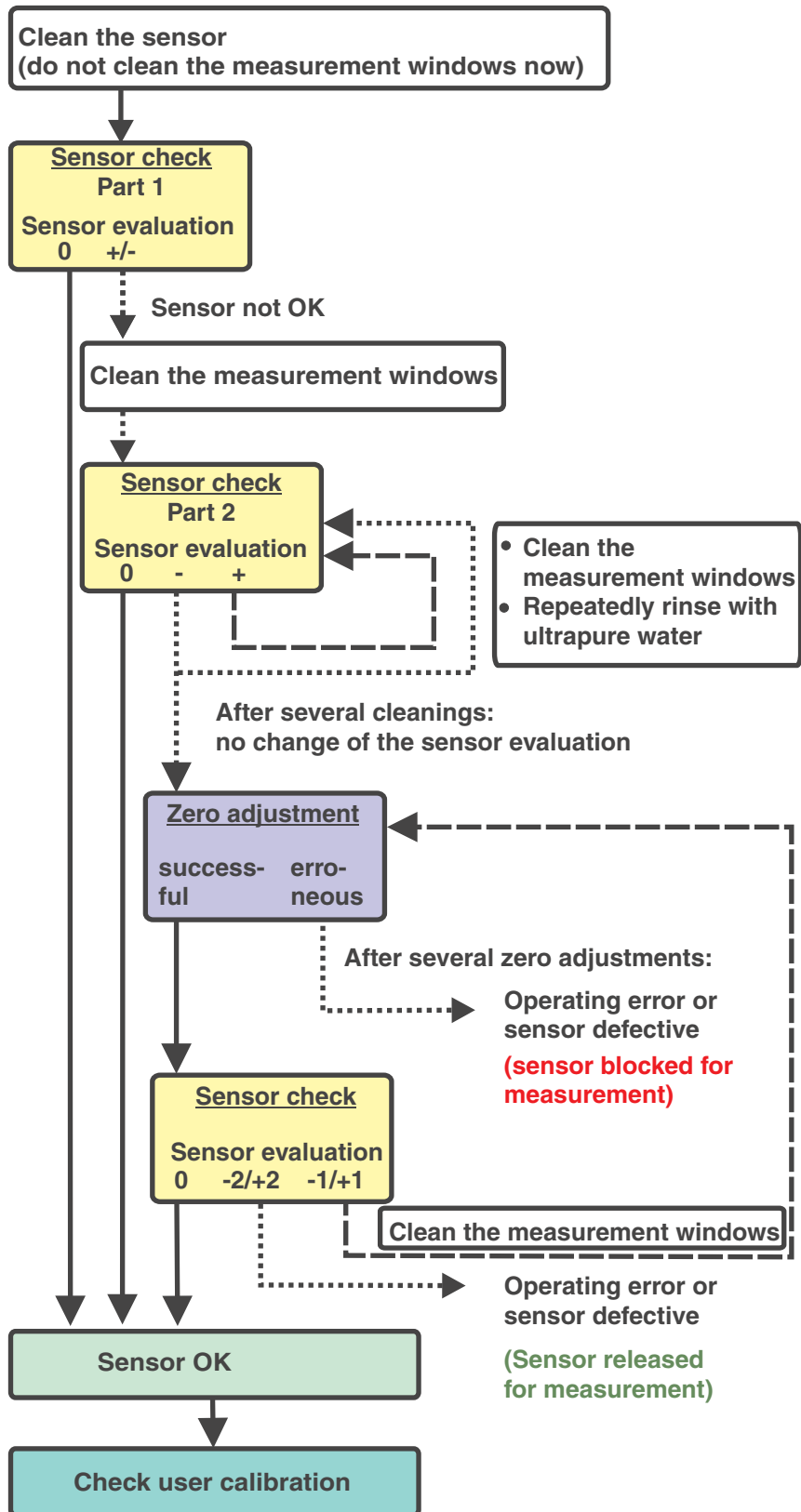

Fig. 4-3 Overview of Sensor check/Zero adjustment and user calibration.

4.3.2 User calibration

Calibration points and value pairs

The adjustment is carried out at one or two points within the measuring range. A value pair is determined at each point. Each value pair consists of the raw value of the UV/VIS sensor and the corresponding reference value.

Each value pair has to be determined at the same time and place as the test sample as possible. At the time of the calibration, the test sample should be in a condition that is typical of the application.

Selection of calibration points

If the required accuracy is low, the default setting of the first value pair can be adopted unchanged. The first value pair is equivalent to the zero point in this case. The second value pair should be close to the working point of the application. This method results in a single-point calibration.

If the application has to cover a wide value range with high measuring accuracy, both value pairs should be used for calibration. When doing so, the calibration value pairs should be determined and input at the limits of the application range if possible.

You obtain samples of different concentrations e.g. by taking two samples during clearly different conditions of the plant (dry period and rain period).



Note

The measurement results will be ever more accurate the closer the composition of the test sample corresponds to the status at the time of the calibration. If there is a fundamental change of the characteristics of the sample, a new calibration may be necessary.

Performing a user calibration

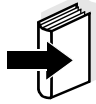

Note

How to navigate to the *Settings of sensors and diff. sensors* menu and the operation of the menu is described in section 3.5.2.

Proceed as follows if you want to perform a user calibration:

1	Bring the sensor into the measuring position.
2	In the <i>Settings of sensors and diff. sensors</i> menu, adjust the <i>Meas. interval</i> setting to the lowest value and the <i>Signal smoothing</i> setting to <i>Off</i> . Subsequently, leave the menu with <i>Save and quit</i> .
3	Switch to the measured value display with \textcircled{M} .
4	Wait for a measurement, read the raw value (without dimension) and note it down. In the case of fluctuating values, observe several measuring cycles and average the individual raw values.
5	Take a sample at the same time as the measurement and as close to the UV/VIS as possible.
6	Determine the reference value and note it down as a value pair together with the raw value.
7	For a two-point calibration: Determine the second value pair (step 4 to step 6).



Note

At least one value pair and a maximum of two value pairs can be entered for a valid calibration. The values have to be in ascending order. Not keeping this order will result in a calibration error.

8	Sort the values pairs in ascending order.
9	In the <i>Settings of sensors and diff. sensors</i> menu, enter the value pair or pairs (see the following table).



Note

The entry of calibration values outside the measuring range leads to a calibration error.



Note

Default values are marked in bold.

Menu item	Settings	Explanations
<i>Cal - # raw value 1</i>	0.00 ... 5000.00	Raw value of the first value pair (lower concentration). For single-point calibration, enter 0.
<i>Cal - ref. value 1</i>	0.00 ... 5000.00	Reference value of the first value pair (lower concentration). For single-point calibration, enter 0.
<i>Cal - # raw value 2</i>	0.00 ... 10.00 ... 5000.00	Raw value of the second value pair (higher concentration) or raw value of the single-point calibration.
<i>Cal - ref. value 2</i>	0.00 ... 10.00 ... 5000.00	Reference value of the second value pair (higher concentration) or reference value of the single-point calibration.

Calibration evaluation

The entered calibration data is checked for plausibility by the system. The check can have the following results:

Display	Meaning/actions
Measured value display	Successful new valid calibration value pairs were entered for the sensor.
"-----"	Calibration value pairs not accepted. Sensor is blocked for measurement. A log book message is generated. Causes: <ul style="list-style-type: none"> ● Ascending order not observed. ● At least one value is outside the measuring range.



Note

Information on the contents and structure of the log book and how you can call it up is given in the LOG BOOK chapter of the IQ SENSOR NET system operating manual.



Note

The user calibration is not recorded in the calibration history. You can, however, view the current value pairs in the *Settings of sensors and diff. sensors* menu at any time.

4.3.3 Sensor check/Zero adjustment

Sensor check and Zero adjustment are carried out using ultrapure water and with the aid of the sensor sleeve.



Quality of the ultrapure water

Preparing the Sensor check/Zero adjustment

Caution

Sensor check and Zero adjustment have to be carried out under absolutely clean conditions. If you do not work carefully enough the Zero adjustment can deteriorate the measuring quality.

Exclusively use distilled or demineralized water that is suitable for analysis purposes. Especially make sure the concentration of metrologically relevant substances (nitrate) is negligible.

Prepare the *Sensor check/Zero adjustment* as follows:

1	Switch to the measured value display with (M) .
2	Select the UV/VIS sensor with (G) .
3	Call up the calibration with (C) . The <i>Maintenance condition: Linked outputs are frozen.</i> window appears.

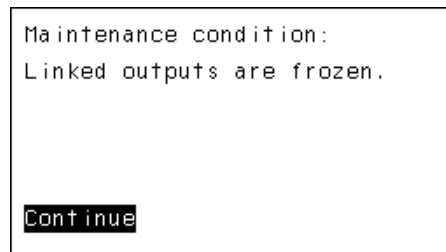

Fig. 4-4 Maintenance condition



Note

When the maintenance condition is activated, linked outputs remain in their current condition. The compressed air cleaning and the determination of measured values are switched off. The measured value display shows a flashing, invalid measured value ("----").

4	Confirm the maintenance condition with (OK) .
5	Confirm the following message, " <i>No user calibration ...</i> " with (OK) .
6	Take the sensor out of the test sample.
7	Unscrew the compressed air connector from the sensor. Caution: Be careful not to lose the two white sealing rings and the screw.

8	<p>Sensor check part 1: Thoroughly clean the sensor enclosure, sensor sleeve and compressed air channels (see section 5.2.3 CLEANING THE SENSOR). Do not clean the measurement window now. To finish the cleaning procedure, thoroughly rinse the entire sensor with deionized water.</p>
9	<p>Sensor check part 2 and further sensor checks: Clean the measurement windows <u>thoroughly</u> (see section 5.2.3 CLEANING THE SENSOR). To finish the cleaning procedure, thoroughly rinse the entire sensor with deionized water.</p>
10	<p>Push the clean sensor sleeve over the sensor so that the opening of the sensor sleeve is in the area of the measuring gap.</p>

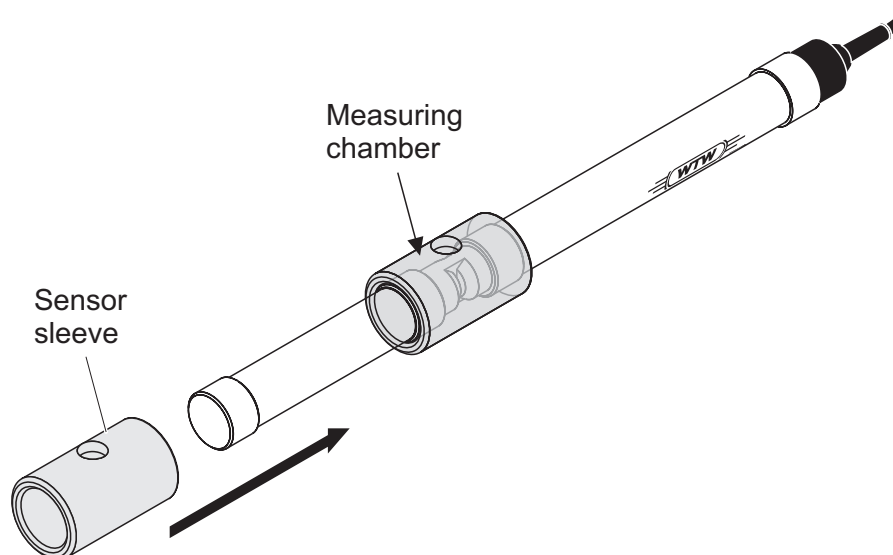





Fig. 4-5 Plugging the sensor sleeve on the sensor

11	<p>Place the sensor horizontally. Turn the sensor in such a way that the measuring gap opening points sideways. Turn the filling opening of the sensor sleeve upward (Fig. 4-5).</p>
12	<p>Rinse the measuring chamber with ultrapure water at least 3 times.</p>
13	<p>Fill the measuring chamber with ultrapure water.</p>
14	<p>If there are any air bubbles on the measuring windows remove them by knocking on the sensor sleeve with a bar.</p>

Carrying out the *Sensor check/Zero adjustment*

15	Select the required option with  and  : <ul style="list-style-type: none"> ● <i>Sensor check</i> ● <i>Zero adjustment</i>
16	Confirm with  . A multipart checklist appears. Use it to check once more whether all preparations have been completed.
17	Confirm each checklist with  until the <i>Start measurement</i> display appears.



Note

Up to this point, you can break off the calibration procedure at any time with the  key. The system continues to work with the old calibration data. However, you have to switch off the maintenance condition in any case.

After starting the calibration with the  key (step 18) you can no longer cancel the calibration.

18	Confirm with  . The measurement is started. After the end of the measurement the result appears. When performing a <i>Zero adjustment</i> , the result is entered in the calibration history at the same time.
----	--

Result after *Sensor check*

Display output	Meaning
Evaluation number 0	<i>Sensor check</i> successful.
Negative evaluation number -1 or -2	<i>Sensor check</i> not successful. Measured values were too high. <u>Possible cause:</u> During the last zero adjustment, the measurement windows were contaminated more than during the current sensor check.
Positive evaluation number +1 or +2	<i>Sensor check</i> not successful. Measured values were too low. <u>Possible cause:</u> The measurement windows are contaminated slightly (+1) or heavily (+2).

The value of the evaluation number quotes the magnitude of the deviation from the last zero measurement:

Value of the evaluation number	Meaning
0	No deviation
1	Small deviation
2	Big deviation

Result after Zero adjustment

Display output	Entry in calibration history	Meaning	Sensor released for measurement
<i>Zero adjustment successful.</i>	OK	<i>Zero adjustment successful.</i>	Yes
<i>Zero adjustment erroneous!</i>	Error	<i>Zero adjustment not successful.</i>	No ("----")



Note

If the result is erroneous please proceed according to the diagram on page 4-5. For a new *Sensor check/Zero adjustment* clean the sensor and all devices once again and take care that the conditions are absolutely clean.

Completing the calibration

After the successful *Sensor check/Zero adjustment*, return to the measurement as follows:

19	Confirm the calibration result with OK .
20	Confirm the message, " <i>After successful calib ...</i> " with OK . The display returns to the measured value display. The measured value flashes because the sensor is still in the maintenance condition.
21	If the calibration was successful, pour away the ultrapure water, remove the sensor sleeve and install the sensor including the compressed air hose at the measuring location.
22	Switch off the maintenance condition (select the UV/VIS sensor with ↺ , press OK and make the setting in the <i>Display/Options</i> menu).
23	Switch to the measured value display with M . The measured value stops flashing.



Note

Store the sensor sleeve in a clean environment, e.g. in a plastic bag, until the next calibration.

4.3.4 Sensor check with standard solutions

To check the sensor with standard solutions, you have to set the *NO₃-N standard* measuring mode. This also applies for checking the zero point with ultrapure water.



Note

The algorithms of all measuring modes except the *NO₃-N standard* mode are adapted to real test samples. With these algorithms it does not make sense to measure standard solutions or ultrapure water.



Procedure

The sensor check is carried out using the sensor sleeve. Basically, the same cleanliness requirements apply as for the *Sensor check/Zero adjustment*. The following course describes the mains steps. For details on individual steps please refer to section 4.3.3.



Note

When switching to the *NO₃-N standard* measuring mode, all links and settings of the outputs are erased.

1	Switch on the maintenance condition (select the UV/VIS sensor with  , press  and make the setting in the <i>Display/Options</i> menu).
2	Take the sensor out of the test sample.
3	Thoroughly clean the entire sensor, especially the measuring gap.
4	Push the sensor sleeve on the sensor and rinse it several times with ultrapure water, then once with standard solution.
5	Place the sensor in a horizontal position and fill the sensor sleeve with standard solution. Remove air bubbles by knocking.
6	In the <i>Settings of sensors and diff. sensors</i> menu, select the <i>NO₃-N standard</i> measuring mode. Subsequently, leave the menu with <i>Save and quit</i> .
7	Switch to the measured value display with  and read the measured value.
8	After the measurement is completed, empty the sensor sleeve, pull it off the sensor and install the sensor including the compressed air hose at the measuring location.
9	Reset the <i>Measuring mode</i> and <i>Cleaning mode</i> to the original setting.
10	Switch off the maintenance condition.

5 Maintenance and cleaning

5.1 Maintenance

The UV/VIS sensor NitraVis 700/x IQ and the MIQ/VIS operate maintenance-free.

5.2 Cleaning

5.2.1 Cleaning the MIQ/VIS

For cleaning the MIQ/VIS, the same basic principles apply as for all MIQ modules. For more detailed information, see chapter MAINTENANCE of the IQ SENSOR NET system operating manual.

5.2.2 Compressed air driven cleaning of the measurement windows

The cleaning system cleans the measurement windows automatically at regular intervals.

5.2.3 Cleaning the sensor



Warning

Risk of injury by active compressed air cleaning function. Before removing the sensor from the test sample, switch off the compressed air cleaning function (e.g. activate the maintenance condition).



Warning

Contact with the test sample can be dangerous for the user! Depending on the type of sample, suitable protective measures must be taken (protective clothing, protective goggles, etc.).



Caution

Never use abrasives or metal brushes to clean the sensor.

To clean the sensor, use the following cleaning agents only:

Contamination	Cleaning agents	Reaction time at room temperature
Water-soluble substances	Tapwater	Any
Greases and oils	<ul style="list-style-type: none"> – Warm water and household washing-up liquid – If the sensor is highly contaminated: methylated spirits 	<ul style="list-style-type: none"> – Any – Maximum 5 minutes
Lime and hydroxide coatings	Acetic acid (10 %)	For a short time, subsequently rinse with tapwater

Cleaning the compressed air channels

The compressed air channels can be cleaned using a pipe-cleaner.

Cleaning the measurement windows

It is not necessary to clean the measurement windows manually if the cleaning efficiency of the compressed air cleaning function is sufficient. If contamination can be noticed or if you suspect contamination because of drifting measured values, please observe the following points:

- Before cleaning the measurement windows the rest of the sensor enclosure should already be clean. Avoid the presence of abrasive particles in the measuring gap.
- For the measurement window, use lint free cleaning tissues soaked with cleaning agent. Direct the cleaning tissue along the measurement windows with the aid of an object of suitable thickness.
- To remove persistent staining from the measurement window, use the cleaning brush available as accessories (see chapter 6).
- If necessary, repeat the cleaning procedure several times and change the cleaning tissue in between.

Finishing the cleaning procedure before a *Sensor check or Zero adjustment*

Residues of cleaning agents can lead to an erroneous sensor calibration (*Sensor check or Zero adjustment*). To complete the cleaning process, thoroughly rinse the sensor several times with deionized water, if you want to calibrate the sensor subsequently.

5.3 Disposal

We recommend to dispose of the sensor and modules as electronic waste.

6 Spare parts, maintenance equipment, accessories

Connection module	Description	Model	Order no.
	Connection module for optical sensors	MIQ/VIS	481 029

Accessories for compressed air cleaning	Description	Model	Order no.
	Valve module	MIQ/CHV PLUS	480 018

Cleaning brush	Description	Model	Order no.
	Brushes for cleaning of UV-VIS sensors, Set with 2 brushes for 1 mm path length	VIS Set Brushes/1mm	481 031
	Brushes for cleaning of UV-VIS sensors, Set with 2 brushes for 5 mm path length	VIS Set Brushes/5mm	481 032



Note

Information on other IQ SENSOR NET accessories is given in the WTW catalog and on the Internet.

7 What to do if...

"----" display (invalid measured value)

Cause	Remedy
<ul style="list-style-type: none"> - User calibration values entered incorrectly - <i>Sensor check/Zero adjustment</i> erroneous 	<ul style="list-style-type: none"> - Correct entry and enter again (section 4.3.2) - Repeat the <i>Sensor check/Zero adjustment</i>. Check the conditions, especially the cleanliness (section 4.3.3)
<ul style="list-style-type: none"> - <i>Zero adjustment</i> still erroneous after several trials 	<ul style="list-style-type: none"> - Contact WTW
<ul style="list-style-type: none"> - Unknown 	<ul style="list-style-type: none"> - See log book

Implausible measured values

Cause	Remedy
<ul style="list-style-type: none"> - Erroneous user calibration 	<ul style="list-style-type: none"> - Repeat user calibration. Make sure the samples for comparison are representative.
<ul style="list-style-type: none"> - Substantial change of test sample (sample matrix) 	<ul style="list-style-type: none"> - Carry out new user calibration
<ul style="list-style-type: none"> - Measurement window dirty 	<ul style="list-style-type: none"> - Clean measurement window
<ul style="list-style-type: none"> - Sensor setting wrong 	<ul style="list-style-type: none"> - Check and, if necessary, correct the <i>Messmodus</i>, <i>Measuring location</i> sensor settings - Carry out new user calibration
<ul style="list-style-type: none"> - Optical system maladjusted, e. g. by unallowed impact of mechanical shock 	<ul style="list-style-type: none"> - Perform a <i>Sensor check/Zero adjustment</i>

Drifting measured values

Cause	Remedy
<ul style="list-style-type: none"> – Cleaning efficiency too low - measurement windows becoming more and more contaminated 	<ul style="list-style-type: none"> – Clean measurement windows (section 5.2.3) – Set longer cleaning duration – Set more frequent cleaning procedures – Increase pressure
<ul style="list-style-type: none"> – Failure of the cleaning system 	<ul style="list-style-type: none"> – Clean measurement windows (section 5.2.3) – Check all components of the cleaning system (compressor, compressed air line, UV/VIS sensor, rinsing openings)
<ul style="list-style-type: none"> – Substantial change of test sample (sample matrix) 	<ul style="list-style-type: none"> – Carry out new user calibration

Display of OFL

Cause	Remedy
<ul style="list-style-type: none"> – Measuring range exceeded 	<ul style="list-style-type: none"> – Check process
<ul style="list-style-type: none"> – Foreign matter in the measuring gap 	<ul style="list-style-type: none"> – Clean measuring gap (section 5.2.3)
<ul style="list-style-type: none"> – Erroneous user calibration 	<ul style="list-style-type: none"> – Repeat user calibration. Make sure the samples for comparison are representative.

Measured values fluctuating heavily

Cause	Remedy
<ul style="list-style-type: none"> – Gas bubbles in front of the measurement windows 	<ul style="list-style-type: none"> – Check the position within the process and the installation position – Increase the adjustment phase after the cleaning process

Measured values too low or too high

Cause	Remedy
<ul style="list-style-type: none"> – Gas bubbles in front of the measurement windows 	<ul style="list-style-type: none"> – Check the installation position of the sensor
<ul style="list-style-type: none"> – Measurement window dirty 	<ul style="list-style-type: none"> – Clean measurement window

Display of <i>ERROR</i>	Cause	Remedy
	<ul style="list-style-type: none"> - No connection between UV/VIS sensor and MIQ/VIS 	<ul style="list-style-type: none"> - Check all electrical connections - Check log book entries and all LEDs on the relevant modules - If the sensor cable is defective return the sensor
	<ul style="list-style-type: none"> - UV/VIS sensor not correctly connected 	<ul style="list-style-type: none"> - Check assignment of terminal connections
	<ul style="list-style-type: none"> - Load at a power supply module too high 	<ul style="list-style-type: none"> - Install another power supply module in the vicinity of the sensor
	<ul style="list-style-type: none"> - IQ SENSOR NET cable towards the MIQ/VIS too long (voltage drop too great) 	<ul style="list-style-type: none"> - Install another power supply module in the vicinity of the sensor
	<ul style="list-style-type: none"> - Electrical connection between power supply module and MIQ/VIS is interrupted 	<ul style="list-style-type: none"> - Check the cable connection step-by-step starting with the power supply module, and replace any defective cable sections. - Check the contacts on the MIQ modules (stack mounting). Clean any dirty contacts. Carefully bend back contact springs that have been pressed flat or bent (pay attention to sufficient spring tension)

8 Technical data

8.1 Sensor

8.1.1 General data

**Dimensions
(in mm)**

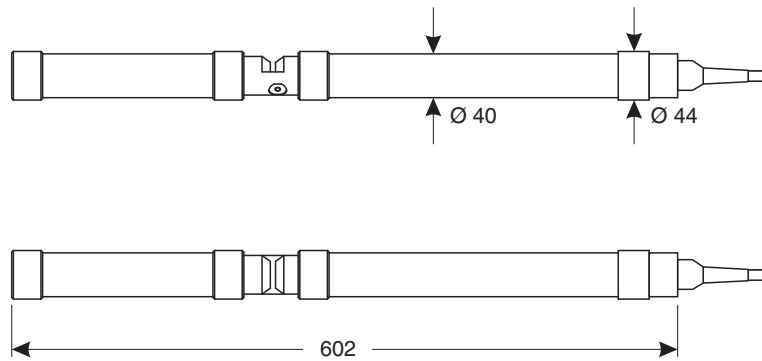

Measuring gap

NitraVis 700/1 IQ	1 mm
NitraVis 700/5 IQ	5 mm

Compressed air hose

6 x 1 mm

Weight

approx. 1100 g (without sensor connection cable)

Connection technique

Connection via 7-pole cable that is permanently fixed on the sensor

Connection cable

Length	15 m
Diameter	7 mm
Smallest allowed bend radius	Permanent bend: 150 mm Single bend: 70 mm
Connection	Open wire ends with wire end sleeves, converted to be connected to the 5-pole terminal strip in the MIQ/VIS.

Materials	Sensor enclosure	Aluminium alloy AlMgSi1, anodized
	Measurement window	Sapphire
	Protective ring	POM
	Cable sheath	PUR
	Compressed air hose	PUR

Storage temperature - 10 ... 50 °C

8.1.2 Electrical data

Electrical data	Power consumption	6.5 W
	Protective class	III

Instrument safety	Applicable norms	– EN 61010-1
	EMC	– EN 61326, Emission Class B – FCC Class A

8.1.3 Measurement conditions

Suitability and areas of application

- Municipal wastewater with a low proportion of industrial wastewater
- The sensor is not suitable for seawater and industrial wastewater.

Measuring medium	pH value	4 - 9
	Salt content	< 5000 mg/l chloride
	Flow rate	< 3 m/s
	Temperature	0 °C ... + 45 °C

Operating position Any

Depth of immersion	min	The measuring gap must be filled with test sample.
	max	10 m depth

Pressure resistance Sensor including connection cable:

Max. allowed overpressure	10 ⁵ Pa (1 bar)
Type of protection	IP 68 (10 ⁵ Pa or 1 bar)

The sensor meets the requirements according to article 3(3) of the guideline 97/23/EC ("pressure equipment guideline").

8.1.4 Measuring ranges and resolution

NitraVis 700/1 IQ	Measuring mode / measuring location	Measuring range	Resolution
	<i>NO3 Inlet</i>	0.0 ... 300.0 mg/l	0.1 mg/l
	<i>NO3 Activation</i>	0.0 ... 300.0 mg/l	0.1 mg/l
	<i>NO3-N Inlet</i>	0.00 ... 60.00 mg/l	0.01 mg/l
	<i>NO3-N Activation</i>	0.00 ... 60.00 mg/l	0.01 mg/l
	<i>NO3-N standard</i>	0.0 ... 100.0 mg/l	0.1 mg/l

NitraVis 700/5 IQ	Measuring mode / measuring location	Measuring range	Resolution
	<i>NO3 Outlet</i>	0.0 ... 250.0 mg/l	0.1 mg/l
	<i>NO3-N Outlet</i>	0.00 ... 50.00 mg/l	0.01 mg/l
	<i>NO3-N standard</i>	0.00 ... 25.00 mg/l	0.01 mg/l



Note

The quoted measuring ranges are nominal measuring ranges that are theoretically possible. In practice, real measuring ranges exist that are given by the limits of photometric determination. The limits are significantly influenced by the light scattering due to solids and the absorption of accompanying substances (sample matrix). Therefore, no fixed measuring range can be determined beforehand.

8.2 MIQ/VIS



Note

General technical data of MIQ modules can be found in the chapter, TECHNICAL DATA of the IQ SENSOR NET system operating manual.

Weight

Approx. 0.5 kg

Electrical data

Nominal voltage	Max. 24 VDC via the IQ SENSOR NET (for more details, see TECHNICAL DATA chapter of the IQ SENSOR NET system operating manual)
Power consumption	0.5 W
Protective class	III

Instrument safety

Applicable norms	<ul style="list-style-type: none"> – EN 61010-1 – UL 3111-1 – CAN/CSA C22.2 No. 1010.1
EMC	<ul style="list-style-type: none"> – EN 61326, Emission Class B – FCC Class A

Terminal connections

IQ SENSOR NET connections	2 Additional connectable SENSORNET terminator (terminating resistor)
Number of relay contacts	1, is exclusively used for the time-controlled, compressed air driven sensor cleaning function
Number of inputs for UV/VIS sensors	1
Terminal type	Screw-type terminal strip, accessible by raising the lid
Terminal ranges	Solid wires: 0.2 ... 4.0 mm ² AWG 24 ... 12 Flexible wires: 0.2 ... 2.5 mm ²
Line diameter of cables that carry line voltage	Europe: 1.5 ... 4.0 mm ² USA: AWG 14 ... 12
Cable feeds	4 cable glands M16 x 1.5 on the underside of the module

Relay	Output	Physically separated from the IQ SENSOR NET
	Max. switching voltage	250 V (AC and DC)
	Max. switching current	2 A (AC and DC)
	Installation requirements	Fuse rating on the operator side: Maximum 2 A
	Relay functions	Control of the sensor cleaning function

9 Indexes

9.1 Explanation of the messages

This chapter contains a list of all the message codes and related message texts that can occur in the log book of the IQ SENSOR NET system for the NitraVis 700/x IQ and the MIQ/VIS.



Note

Information on

- the contents and structure of the log book and
- the structure of the message code

is given in the LOG BOOK chapter of the IQ SENSOR NET system operating manual.

Component codes of the components

The last three digits of the message code form the component code. It identifies the component (active component) that caused the message:

Component code	Component
371	NitraVis 700/1 IQ
372	NitraVis 700/5 IQ
511	MIQ/VIS



Note

Some error messages contain an internal error code, starting with "#".

9.1.1 Error messages

Message code

EA1371 / EA1372

Message text

Meas. range exceeded or undercut
 * Check process
 * Select other meas. range

EAE371 / EAE372

Measurement out of order #-4
 * Check process (TSS or measured value too high)
 * Select measuring location free of air bubbles
 * Clean sensor
 * Remove foreign matter from measuring gap
 * Optimize cleaning settings
 * Carry out sensor test and zero adjustment with ultrapure water

Message code	Message text
EAF371 / EAF372	<i>Optical measuring range exceeded #-10</i> <i>* Check process (TSS or measured value too high)</i> <i>* Select measuring location free of air bubbles</i> <i>* Remove foreign matter from measuring gap</i> <i>* Clean sensor</i> <i>* Optimize cleaning settings</i> <i>* Switch on signal smoothing, increase response time</i>
EAI371 / EAI372	<i>Zero adjustment erroneous</i> <i>* Clean sensor and sensor sleeve repeatedly</i> <i>* Position sensor sleeve according to operating manual</i> <i>* Rinse measuring chamber with ultrapure water several times</i> <i>* Fill measuring chamber with ultrapure water</i> <i>* Repeat zero adjustment</i>
EAJ371 / EAJ372	<i>Sensor temperature too high, no operation possible #xxx</i> <i>* Check process and application</i>
EAK371 / EAK372	<i>Sensor temperature too low, no operation possible #xxx</i> <i>* Check process and application</i>
EAM371 / EAM372	<i>Meas. range exceeded or undercut</i> <i>* Check process</i>
EC3371 / EC3372	<i>User calibration erroneous,</i> <i>Check raw value / reference value pairs</i> <i>* Set all values within the measuring range</i> <i>(see operating manual)</i> <i>* Enter value pairs in ascending order</i>
EIA511	<i>Malfunction, no operation possible</i> <i>* Connect sensor cable to MIQ/VIS correctly and securely</i> <i>* Provide voltage supply to MIQ/VIS and sensor</i> <i>* Sensor or MIQ/VIS defective</i> <i>* Contact WTW</i>
EIB371 / EIB372	<i>Sensor voltage too low #xxx</i> <i>* Check installation and cable lengths,</i> <i>Follow installation instructions</i> <i>* Power unit(s) overloaded, add power unit(s)</i> <i>* Check terminal and module connections</i> <i>* Defective components, replace components</i>
EIC371 / EIC372	<i>Sensor voltage too low, no operation possible #xxx</i> <i>* Check installation and cable lengths,</i> <i>Follow installation instructions</i> <i>* Power unit(s) overloaded, add power unit(s)</i> <i>* Check terminal and module connections</i> <i>* Defective components, replace components</i>

Message code	Message text
EID371 / EID372	<i>Sensor voltage too high, no operation possible #xxx * MIQ/VIS defective</i>
ESF371 / ESF372	<i>Sensor defective, no operation possible #xxx * Contact WTW</i>
ESG511	<i>Sensor incompatible, no operation possible</i>
ESH511	<i>Sensor incompatible, no operation possible #xxx</i>

9.1.2 Info messages

Message code	Message text
IAB371 / IAB372	(here, all relevant software versions of the NitraVis 700/x IQ are recalled)
IAC371 / IAC372	<i>Zero adjustment was successfully carried out * Carry out sensor check * If required, carry out new user calibration</i>
IAD371 / IAD372	<i>Measuring location was changed, sensor check required * Prepare and carry out sensor check according to operating manual * Repeat sensor check if required * In the case of several errors carry out zero adjustment * After zero adjustment carry out another sensor check</i>
IAG371 / IAG372	<i>Optical measuring range undercut #-11 * Check process * Immerse sensor in test sample * Switch on signal smoothing, increase response time</i>
IAH371 / IAH372	<i>Sensor check erroneous * Clean sensor and sensor sleeve thoroughly and repeatedly * Position sensor sleeve according to operating manual * Rinse measuring chamber with ultrapure water several times * Fill measuring chamber with ultrapure water * Repeat sensor check</i>
IAL371 / IAL372	<i>Recalculated minimum interval time of %ld minutes</i>
IS3371 / IS3372	<i>Unknown Error #xxx</i>

9.2 Status info

The status info is a coded piece of information on the current status of a sensor. Each sensor sends this status info to the controller. The status info of sensors consists of 32 bits, each of which can have the value 0 or 1.

**Status info,
general structure**

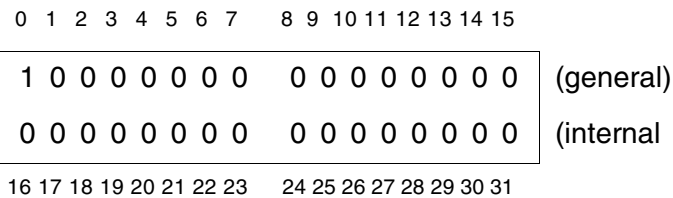

The bits 0 - 15 are reserved for general information.
The bits 16 - 21 are reserved for internal service information.

You obtain the status info:

- by a manual query in the *Settings/Service/List of all components* menu (see system operating manual)
- by an automated query
 - of a superordinate process control (e. g. when connected to the Profibus)
 - of the IQ Data Server (see IQ SENSOR NET Software Pack operating manual)



Note

The evaluation of the status info, e.g. in the case of an automated query, has to be made individually for each bit.

**Status-Info
NitraVis 700/x IQ**

Status bit	Explanation
Bit 0	<i>Component hardware defective</i>
Bit 1-31	-

10 Appendix: Glossary

Absorbance (Absorption)	Attenuation of the light beam when it penetrates the sample.
Adjusting	To manipulate a measuring system so that the relevant value (e. g. the displayed value) differs as little as possible from the correct value or a value that is regarded as correct, or that the difference remains within the tolerance.
Calibration	Comparing the value from a measuring system (e. g. the displayed value) to the correct value or a value that is regarded as correct. Often, this expression is also used when the measuring system is adjusted at the same time (see adjusting).
Calibration value pair	Value pair consisting of the raw value measured by the UV/VIS sensor, and a reference value measured e.g. by a laboratory determination. The calibration value pairs are the result of the user calibration.
Concentration	Mass or amount of a dissolved substance per volume, e. g. in g/l or mol/l.
Measured parameter	The measured parameter is the physical dimension determined by measuring, e. g. pH, conductivity or D.O. concentration.
Measured value	The measured value is the special value of a measured parameter to be determined. It is given as a combination of the numerical value and unit (e. g. 3 m; 0.5 s; 5.2 A; 373.15 K).
Measured value	The measured value is determined from the raw value taking into account the data from a user calibration. The measured value is displayed together with the raw value in the measured value display.
Measuring gap	The measuring gap is between the two measurement windows. In the measuring gap, the light beam penetrates the test sample.
Measuring system	The measuring system comprises all the devices used for measuring, e. g. measuring instrument and sensor. In addition, there is the cable and possibly an amplifier, terminal strip and armature.
NO₃-N	The proportion of nitrogen coming from nitrate.
Raw value	The raw value is determined from the spectrum while taking into account the data from the zero adjustment. The raw value is displayed on the right side of the measured value in the measured value display.
Reference sample	Random sample of the test sample for comparative chemical-analytical laboratory analyses intended for user calibration.

Resolution	Smallest difference between two measured values that can be displayed by a measuring instrument.
Sample matrix	Composition of the test sample of different individual substances.
Spectrum	Distribution of the absorbance depending of the wavelength. With the aid of the zero adjustment and user calibration, the measured values are calculated from the spectrum.
Test sample	Designation of the test sample ready to be measured.
Zero adjustment	Measuring and saving the absorbance spectrum of ultrapure water. Defines the zero point in the spectrum for all wavelengths. The light beam is not alleviated at the zero point. The zero point influences the calculation of the raw value.



Wissenschaftlich-Technische Werkstätten GmbH

Dr.-Karl-Slevogt-Straße 1
D-82362 Weilheim

Germany

Tel: +49 (0) 881 183-0
+49 (0) 881 183-100
Fax: +49 (0) 881 183-420
E-Mail: Info@WTW.com
Internet: <http://www.WTW.com>